

TX TPER WATERSTOP

CHEMICAL RESISTANT WATERSTOP



PRODUCT DESCRIPTION

CJSA TX TPER Waterstop is a specially designed profile for use in construction or expansion/isolation joints in concrete where you require a waterstop in the joint between an existing structure to a new structure.

TPER (Thermoplastic Elastomeric Rubber) Waterstops lead the way in high technology waterstops that have been designed for use in primary and secondary containment structures where a highly chemical resistant waterstop is required to prevent the flow or migration of fluid through joints in concrete.



ADVANTAGES

- Ability to waterstop the joint where traditional waterstop profiles or other waterstop systems cannot be placed
- Able to accommodate large movements in expansion/isolation joints due to its innovative design
- Able to accommodate longitudinal, lateral and differential movements in expansion/isolation joints
- A high performance material produced from virgin TPER compound (refer to material specification) giving long-term integrity and durability over time. No scrap or recycled TPER's are used
- Water stops the joint and allows it to expand and contract freely from movements caused by thermal fluctuations and serviceability loads from within the structure



AREAS OF APPLICATION

All types of construction or expansion/isolation joints in concrete where an existing structure and new structure meet and require a waterstop.

Note: The product's design and performance, its intended use, installation and final confirmation and approval for use, must be provided by the project's Design Engineer and Project Manager.



TYPICAL APPLICATIONS

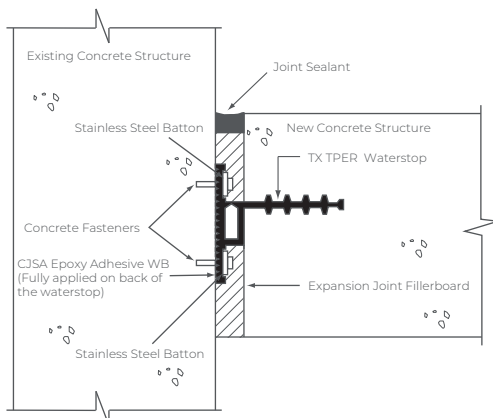

EXISTING WALL TO NEW SLAB CONNECTION
(EXPANSION/ISOLATION JOINT)

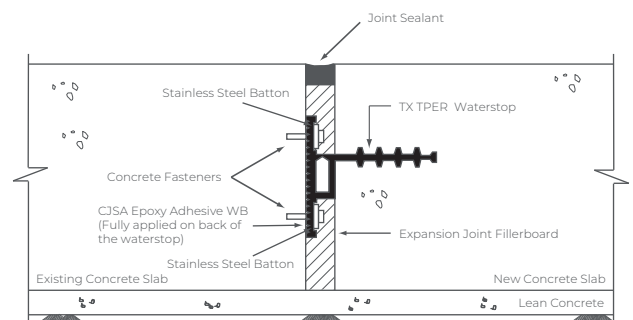

EXISTING BASE SLAB TO NEW BASE SLAB CONNECTION
(EXPANSION/ISOLATION JOINT)



TECHNICAL FEATURES

COLOUR	Black
PACKAGING	100mm & 150mm Width - 3 metre per length
WEIGHT PER LENGTH	Dependent upon profile type
STORAGE CONDITIONS & SHELF LIFE	5 years from the date of production if stored properly in original, unopened and undamaged sealed packaging, in dry conditions out of direct sunlight at temperatures between +10°C and +40°C
MATERIAL TYPE	TPER (Thermoplastic Elastomeric Rubber)
WELDING TEMPERATURES	Approximately 200°C
SERVICE TEMPERATURE RANGE	-25°C to +135°C



PHYSICAL PROPERTIES

PROPERTY	TEST METHOD	RESULT
TENSILE STRENGTH, MPa	BS ISO 37 : 2011	6.9
ELONGATION AT BREAK, %	BS ISO 37 : 2011	560
WATER ABSORPTION AT 23°C, CHANGE IN MASS, %	BS ISO 1817 : 2015	0
SPECIFIC GRAVITY	BS ISO 2781 : 2008	1.00
HARDNESS, IRHD	BS ISO 48 : 2010	82
OZONE RESISTANCE	ASTM D1171	Passed, no cracking at 500 pphm

Note: Refer to CJSA's in house Certificate of Analysis (COA) dated 30/12/2016 for test results pertaining to the above. A COA is conducted on every batch of raw material that is used in the production of **TX TPER Waterstop**. Independent laboratory test results are also available upon request. Project specific material properties can be custom compounded to suit. Material properties can vary between batches.



PROFILE DRAWINGS

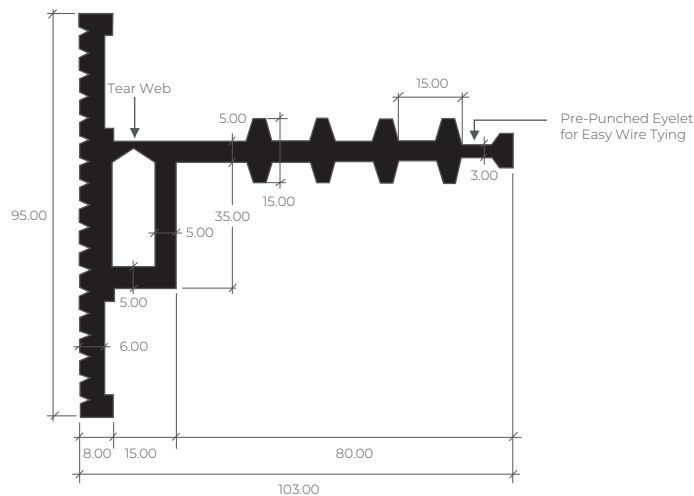

TX-100





PROFILE DRAWINGS (continued)

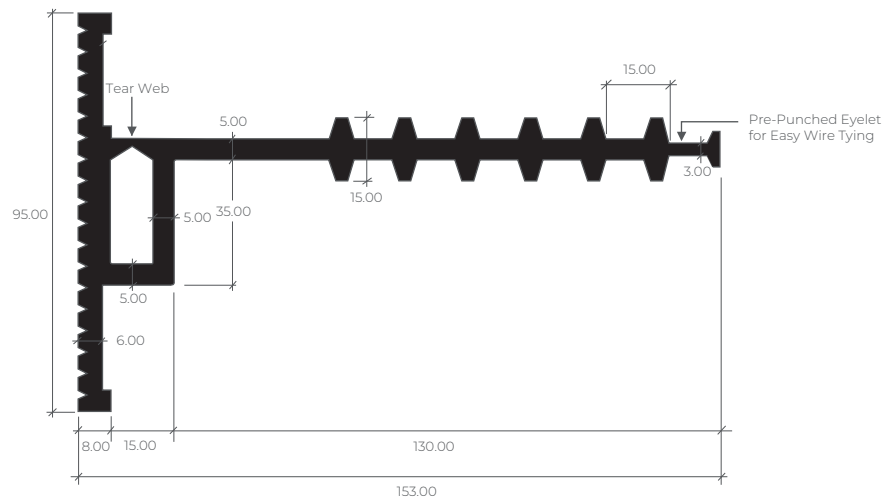

TX-150

Note : TX TPER Waterstop is available in 3 metre lengths



SITE JOINING

CJSA recommends the use of its specialised welding equipment for on-site welding which consists of thermostatically-controlled Welding Irons and special Welding Jigs (each type of TX TPER Waterstop requires its own welding jig to suit the particular shape). On-site joining is a simple exercise using CJSA Heat Welding Equipment comprising of an adjustable Welding Jig and Welding Iron. The ends of the waterstop are cut square and placed into the adjustable Welding Jig, then push the ends of the waterstop against the Welding Iron and bring the two ends together until the molten ends of the TX TPER Waterstop fuse together. When ordering Welding Equipment, please advise profile number of the waterstop required.



INSTALLATION PROCEDURES

1. Installation of TX TPER Waterstop must be in accordance with our recommended installation procedures (refer to our "Installation Method Guideline").
2. TX TPER Waterstop and its ancillary items for installation must be procured from CJSA (refer to our "Installation Method Guideline-Ancillary Items List").
3. The concrete must be fully vibrated around the TX TPER Waterstop to help achieve ultimate sealing capabilities and full integration of the waterstop into the structure.
4. Joining of TX TPER Waterstop must be performed by heat welding with special equipment provided by CJSA (refer to our on site joining/welding method guideline).
5. Factory fabricated intersections must be used to connect traditional types of PVC waterstop to TX TPER Waterstop. Special intersections will be required to join the waterstops that are being used in the construction or expansion joints that run perpendicular into the construction, expansion/isolation joint where the TX TPER Waterstop is to be placed. Contact CJSA for further details.
6. All the joints of the concrete structure that run perpendicular into the construction or expansion/isolation joint where the TX TPER Waterstop is to be used, must have waterstops in them. If they are construction joints, then traditional construction joint waterstops or our Superswell 47B Hydrophilic Waterstop can be used (refer to our recommended installation procedures). If traditional waterstops are to be used, then refer to No. 4 above.

Note : The product's design and performance, its intended use, installation and final confirmation and approval for use, must be provided by the project's Design Engineer and Project Manager.





DESIGN PARAMETERS

1. **TX TPER Waterstop** should only be installed into an expansion/isolation joint with a maximum width of 30mm and with maximum movement of 50mm. If a wider joint or wider range of movement is required, please consult **CJSA**.
2. **TX TPER Waterstop** must be installed by skilled installers and must be in accordance with **CJSA**'s recommended installation procedures (refer to our "Installation Method Guideline").
3. **TX TPER Waterstop** and its ancillary items for installation must be procured from **CJSA**. (refer to our "Installation Method Guideline-Ancillary Items List").

Note: *Proposal, specification, design and end use of this product must be fully endorsed and approved by the Design Engineer.*



WRITTEN SPECIFICATION

Waterstop shall be **TX TPER Waterstop** (state profile type) as supplied by **CJSA** with dimensions, shape and material properties as illustrated/mentioned in their brochure. All installation and joining procedures must be according to their recommendations and requirements, and also approved by the project's design engineer.



HEALTH AND SAFETY INFORMATION

Joining of **TX TPER Waterstops** is performed by heat welding which results in the discharge of hydrogen chloride mist and vapour. In confined spaces or in still air conditions, the use of a ventilation fan or suitable respirator should be used, and the advice and approval of the site Safety Supervisor is essential. For further information or advice on health and safety precautions, safe handling, storage and correct disposal of products, please refer to the most recent product Safety Data Sheet (SDS) which is available upon request.



DISCLAIMER

The information and the recommendations relating to the application and end use of this product are given in good faith and are based on the information provided by the manufacturer of the product and/or the Company's current knowledge and experience in connection with the product when properly stored, handled and applied under normal conditions and no liability of final function at the job site is assumed. In practice, the differences in materials, substrates and actual site conditions are such that no warranty in respect of merchantability of, or fitness for, particular purpose, nor any liability arising out of any legal relationship whatsoever, can be inferred either from this information, or from any written and/or oral recommendations, or from any other advice offered by the Company. The Company also has no express or implied knowledge of any particular purpose for which the product is required and any such information given will not be taken into account in the supply of this product. No responsibility or liability by the Company will be accepted for misuse, misreading or derivation from recommended guidelines in respect of this product and the user shall determine the suitability of the product for his intended use and assume all risks and liability in connection therewith. The information contained in our brochure may change at any time without notice. Any use of this product, **TX TPER Waterstops**, in any application should be approved as suitable for use/application by the Design Engineer and Project Manager.

Effective Date: 14 NOVEMBER 2019

CJSA

- Unit 2, 18 Farrow Circuit Seaford Rise, South Australia 5169, AUSTRALIA
- +61 432 423 103
- admin@cjsa.net.au

